

B1b Clamping Components - SERIES **V9M** Handwheel, 9 Points, Threaded Stud

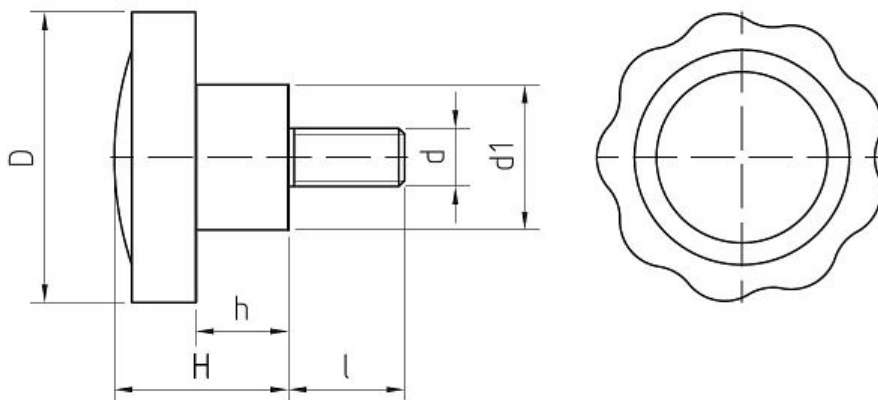

Characteristics

Main Part Material: Black Phenoplast, solvents, oils, greases and other chemical agents proof

Metallic Part Material & Finishing: Zinc Plated Threaded Steel Bolt

Code	D	d	d1	H	h	l	Weight gr.	Packing Pcs.
B1V9M200415	20	04MA	13	17	8	15	7	20
B1V9M200420	20	04MA	13	17	8	20	7	20
B1V9M200425	20	04MA	13	17	8	25	7	20
B1V9M200510	20	05MA	13	17	8	10	8	20
B1V9M200515	20	05MA	13	17	8	15	8	20
B1V9M200520	20	05MA	13	17	8	20	8	20
B1V9M200525	20	05MA	13	17	8	25	10	20
B1V9M200530	20	05MA	13	17	8	30	11	20
B1V9M200612	20	06MA	13	17	8	12	9	20
B1V9M200615	20	06MA	13	17	8	15	10	20
B1V9M200620	20	06MA	13	17	8	20	11	20
B1V9M200625	20	06MA	13	17	8	25	12	20
B1V9M200630	20	06MA	13	17	8	30	12	20
B1V9M200640	20	06MA	13	17	8	40	13	20
B1V9M200820	20	08MA	13	17	8	20	15	20
B1V9M250430	25	04MA	16	18	9	30	9	20
B1V9M250510	25	05MA	16	18	9	10	9	20
B1V9M250515	25	05MA	16	18	9	15	10	20
B1V9M250520	25	05MA	16	18	9	20	12	20
B1V9M250530	25	05MA	16	18	9	30	14	20
B1V9M250540	25	05MA	16	18	9	40	15	20
B1V9M250550	25	05MA	16	18	9	50	15	20
B1V9M250612	25	06MA	16	18	9	12	12	20
B1V9M250615	25	06MA	16	18	9	15	13	20
B1V9M250620	25	06MA	16	18	9	20	16	20
B1V9M250630	25	06MA	16	18	9	30	15	20
B1V9M250640	25	06MA	16	18	9	40	17	20

Code	D	d	d1	H	h	I	Weight gr.	Packing Pcs.
B1V9M250650	25	06MA	16	18	9	50	19	20
B1V9M250815	25	08MA	16	18	9	15	18	20
B1V9M250818	25	08MA	16	18	9	18	18	20
B1V9M250820	25	08MA	16	18	9	20	19	20
B1V9M250830	25	08MA	16	18	9	30	21	20
B1V9M250840	25	08MA	16	18	9	40	24	20
B1V9M300525	30	05MA	17	23	8	25	18	20
B1V9M300615	30	06MA	17	23	8	15	19	20
B1V9M300620	30	06MA	17	23	8	20	20	20
B1V9M300625	30	06MA	17	23	8	25	21	20
B1V9M300630	30	06MA	17	23	8	30	21	20
B1V9M300650	30	06MA	17	23	8	50	22	20
B1V9M300815	30	08MA	17	23	8	15	22	20
B1V9M300820	30	08MA	17	23	8	20	26	20
B1V9M300830	30	08MA	17	23	8	30	27	20
B1V9M400625	40	06MA	21	24	14	25	25	20
B1V9M400630	40	06MA	21	24	14	30	26	20
B1V9M400640	40	06MA	21	24	14	40	27	20
B1V9M400650	40	06MA	21	24	14	50	28	20
B1V9M400815	40	08MA	21	24	14	15	28	20
B1V9M400820	40	08MA	21	24	14	20	29	20
B1V9M400830	40	08MA	21	24	14	30	33	20
B1V9M400840	40	08MA	21	24	14	40	36	20
B1V9M400850	40	08MA	21	24	14	50	38	20
B1V9M400860	40	08MA	25	24	14	60	42	20
B1V9M401020	40	10MA	25	24	14	20	35	20
B1V9M401025	40	10MA	25	24	14	25	37	20
B1V9M401030	40	10MA	25	24	14	30	40	20
B1V9M401050	40	10MA	25	24	14	50	50	20
B1V9M500820	50	08MA	25	30	16	20	50	20
B1V9M500830	50	08MA	25	30	16	30	52	20
B1V9M500840	50	08MA	25	30	16	40	55	20
B1V9M501020	50	10MA	25	30	16	20	58	20
B1V9M501030	50	10MA	25	30	16	30	60	20
B1V9M501040	50	10MA	25	30	16	40	65	20
B1V9M501050	50	10MA	25	30	16	50	71	20
B1V9M501250	50	12MA	25	30	16	50	88	20
B1V9M600830	60	08MA	27	34	18	30	68	20
B1V9M601030	60	10MA	27	34	18	30	76	20
B1V9M601040	60	10MA	27	34	18	40	80	20
B1V9M601050	60	10MA	27	34	18	50	84	20
B1V9M601215	60	12MA	27	34	18	15	95	20
B1V9M601230	60	12MA	27	34	18	30	90	20
B1V9M601250	60	12MA	27	34	18	50	105	20
B1V9M701040	70	10MA	31	35	19	40	103	20
B1V9M701230	70	12MA	31	35	19	30	120	20
B1V9M701450	70	14MA	31	35	19	50	140	20

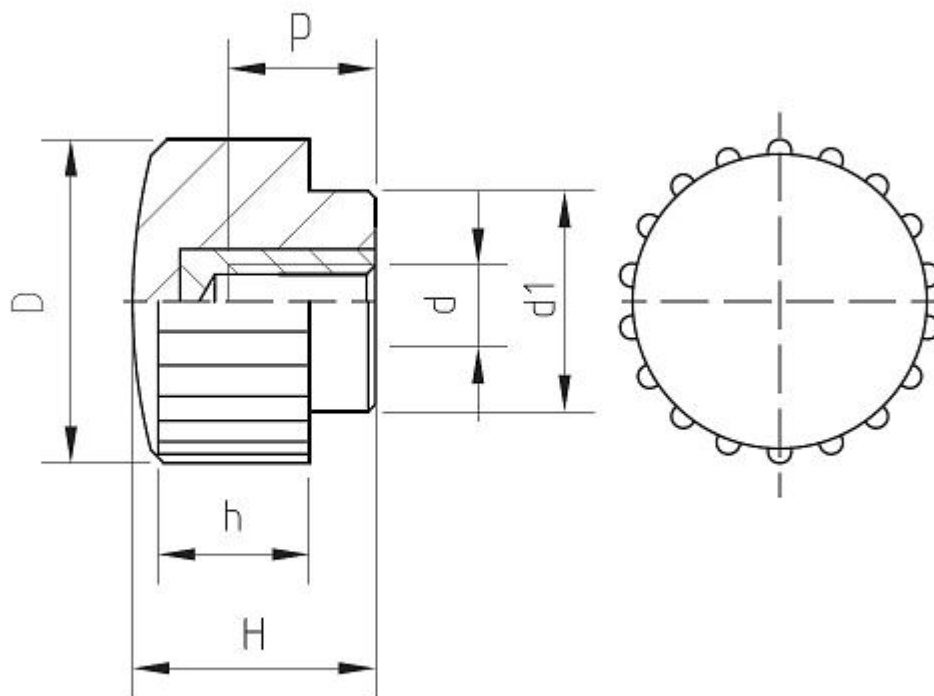

Characteristics

Main Part Material: Black Phenoplast, solvents, oils, greases and other chemical agents proof

Metallic Part Material & Finishing: Brass Insert, Threaded Blind Hole

Code	D	d	d1	H	h	P	Weight gr.	Packing Pcs.
B1VZB1503	15	03MA	11	11	8	8	3	20
B1VZB1504	15	04MA	11	11	8	8	4	20
B1VZB1505	15	05MA	11	11	8	8	4	20
B1VZB1506	15	06MA	11	11	8	8	4	20
B1VZB1804	18	04MA	13	14	10	8	5	20
B1VZB1805	18	05MA	13	14	10	8	5	20
B1VZB1806	18	06MA	13	14	10	8	5	20
B1VZB2206	22	06MA	15	16	10	10	9	20
B1VZB2208	22	08MA	15	16	10	10	9	20

B1b Clamping Components - SERIES VZBP Thumb Knob, Threaded Thru-Insert

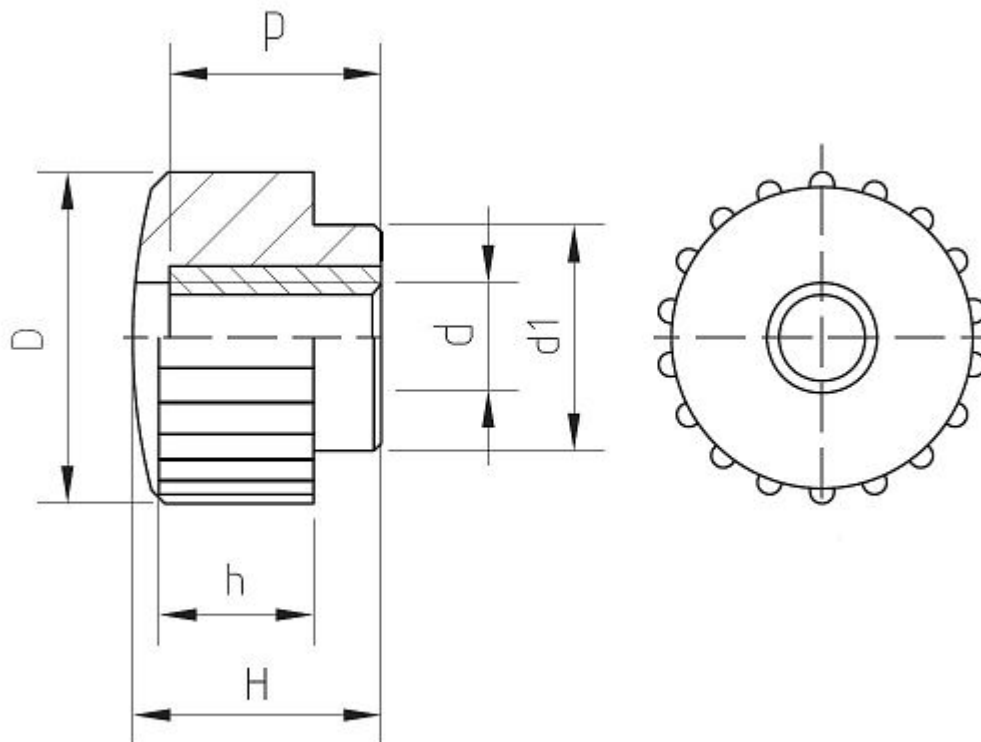

Characteristics

Main Part Material: Black Phenoplast, solvents, oils, greases and other chemical agents proof

Metallic Part Material & Finishing: Brass Insert, Threaded Thru-Hole

Code	D	d	d1	H	h	P	Weight gr.	Packing Pcs.
B1VZBP1503	15	03MA	11	11	8	10	4	20
B1VZBP1504	15	04MA	11	11	8	10	5	20
B1VZBP1505	15	05MA	11	11	8	10	4	20
B1VZBP1506	15	06MA	11	11	8	10	4	20
B1VZBP1804	18	04MA	13	14	10	10	5	20
B1VZBP1805	18	05MA	13	14	10	10	6	20
B1VZBP1806	18	06MA	13	14	10	10	6	20
B1VZBP2206	22	06MA	15	16	10	15	8	20
B1VZBP2208	22	08MA	15	16	10	15	8	20

B1b Clamping Components - SERIES VZM Thumb Knob, Threaded Stud

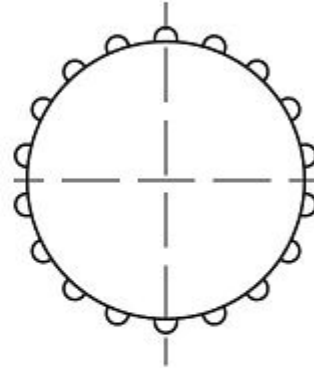
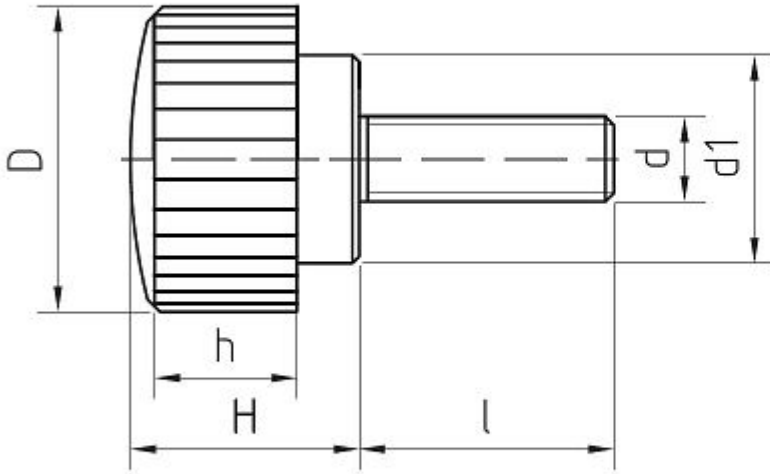

Characteristics

Main Part Material: Black Phenoplast, solvents, oils, greases and other chemical agents proof

Metallic Part Material & Finishing: Zinc Plated Threaded Steel Bolt

Code	D	d	d1	H	h	l	Weight gr.	Packing Pcs.
B1VZM150310	15	03MA	11	11	8	10	3	20
B1VZM150410	15	04MA	11	11	8	10	3	20
B1VZM150415	15	04MA	11	11	8	15	4	20
B1VZM150430	15	04MA	11	11	8	30	4	20
B1VZM150510	15	05MA	11	11	8	10	5	20
B1VZM150512	15	05MA	11	11	8	12	5	20
B1VZM150515	15	05MA	11	11	8	15	5	20
B1VZM150540	15	05MA	11	11	8	40	9	20
B1VZM180410	18	04MA	13	14	10	10	5	20
B1VZM180415	18	04MA	13	14	10	15	6	20
B1VZM180420	18	04MA	13	14	10	20	6	20
B1VZM180510	18	05MA	13	14	10	10	6	20

Code	D	d	d1	H	h	l	Weight gr.	Packing Pcs.
B1VZM180515	18	05MA	13	14	10	15	7	20
B1VZM180520	18	05MA	13	14	10	20	8	20
B1VZM180525	18	05MA	13	14	10	25	10	20
B1VZM180612	18	06MA	13	14	10	12	8	20
B1VZM180615	18	06MA	13	14	10	15	9	20
B1VZM180620	18	06MA	13	14	10	20	10	20
B1VZM180625	18	06MA	13	14	10	25	10	20
B1VZM180630	18	06MA	13	14	10	30	11	20
B1VZM180650	18	06MA	13	14	10	50	15	20
B1VZM220410	22	04MA	15	16	10	10	7	20
B1VZM220420	22	04MA	15	16	10	20	7	20
B1VZM220520	22	05MA	15	16	10	20	8	20
B1VZM220615	22	06MA	15	16	10	15	11	20
B1VZM220630	22	06MA	15	16	10	30	13	20
B1VZM220650	22	06MA	15	16	10	50	14	20
B1VZM220815	22	08MA	15	16	10	15	15	20
B1VZM220820	22	08MA	15	16	10	20	16	20
B1VZM220830	22	08MA	15	16	10	30	20	20
B1VZM220850	22	08MA	15	16	10	50	22	20

B1b Clamping Components - SERIES VZTB Nylon Thumb Knob, Threaded Blind Insert

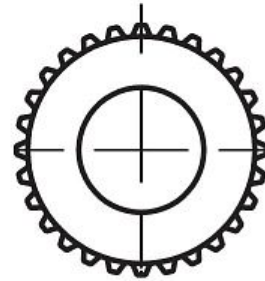
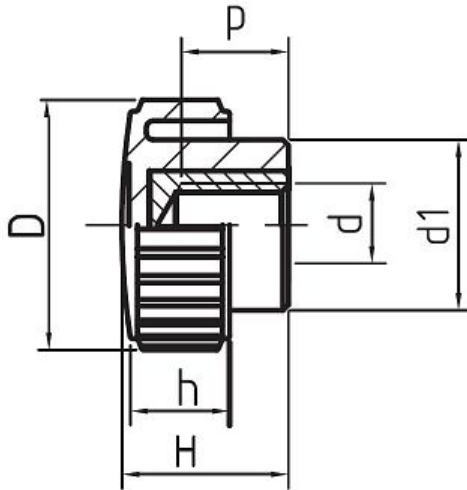

Characteristics

Main Part Material: Black Technopolymer, fiberglass-reinforced, solvents, oils, greases and other chemical agents proof

Metallic Part Material & Finishing: Brass Insert, Threaded Blind Hole

Code	D	d	d1	H	h	P	Weight gr.	Packing Pcs.
B1VZTB1804	18	M04	12	11	5	8	6	20
B1VZTB1805	18	M05	12	11	5	8	7	20
B1VZTB1806	18	M06	12	11	5	8	8	20

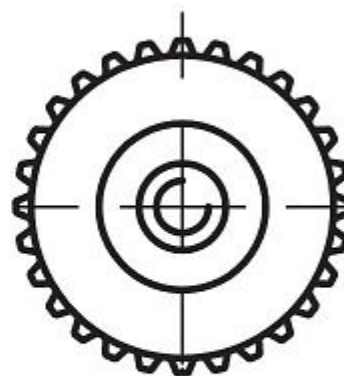
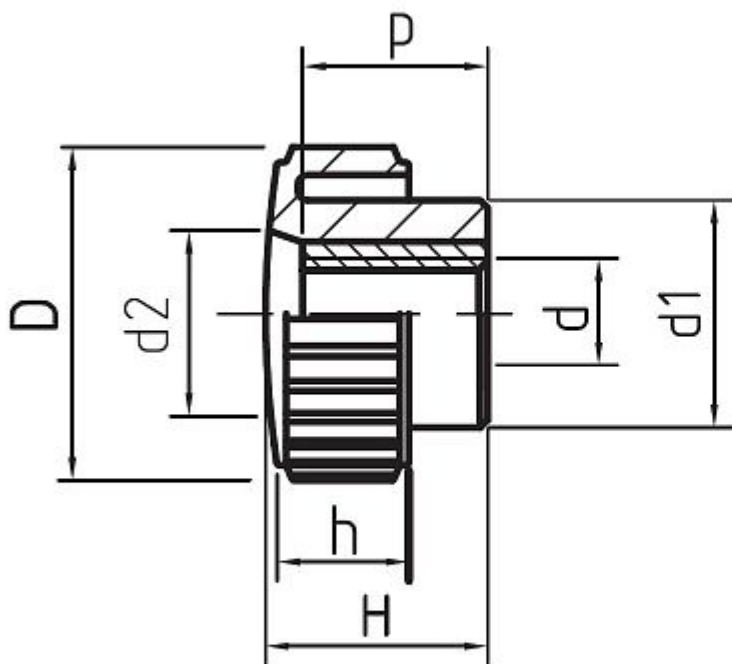

Characteristics

Main Part Material: Black Technopolymer, fiberglass-reinforced, solvents, oils, greases and other chemical agents proof

Metallic Part Material & Finishing: Brass Insert, Threaded Thru-Hole

Code	D	d	d1	H	h	P	Weight gr.	Packing Pcs.
B1VZTBP1804	18	M04	12	11	5	10	6	20
B1VZTBP1805	18	M05	12	11	5	10	7	20
B1VZTBP1806	18	M06	12	11	5	10	8	20

B1b Clamping Components - SERIES **VZTM** Nylon Thumb Knob, Threaded Stud

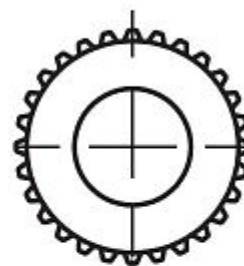
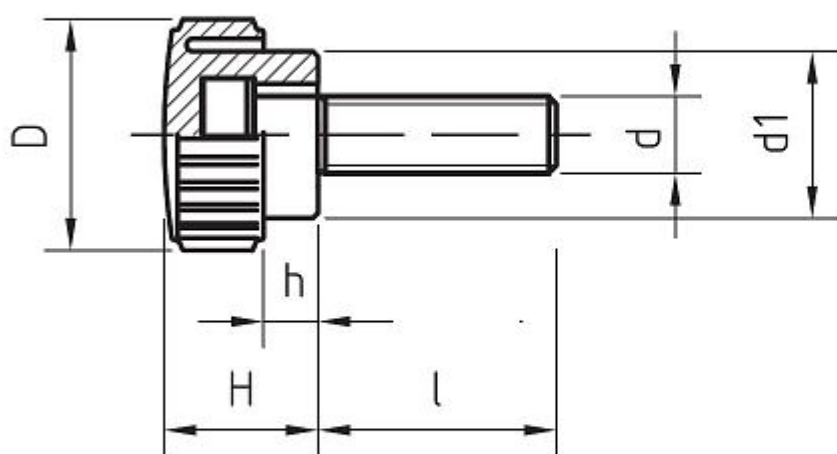

Characteristics

Main Part Material: Black Technopolymer, fiberglass-reinforced, solvents, oils, greases and other chemical agents proof

Metallic Part Material & Finishing: Zinc Plated Threaded Steel Bolt

Code	D	d	d1	H	h	l	Weight gr.	Packing Pcs.
B1VZTM180410	18	M04	12	11	5	10	6	20
B1VZTM180415	18	M04	12	11	5	15	6	20
B1VZTM180420	18	M04	12	11	5	20	6	20
B1VZTM180430	18	M04	12	11	5	30	6	20
B1VZTM180440	18	M04	12	11	5	40	6	20
B1VZTM180450	18	M04	12	11	5	50	6	20
B1VZTM180510	18	M05	12	11	5	10	7	20
B1VZTM180515	18	M05	12	11	5	15	7	20
B1VZTM180520	18	M05	12	11	5	20	7	20
B1VZTM180530	18	M05	12	11	5	30	7	20
B1VZTM180540	18	M05	12	11	5	40	7	20
B1VZTM180550	18	M05	12	11	5	50	7	20
B1VZTM180610	18	M06	12	11	5	10	8	20
B1VZTM180615	18	M06	12	11	5	15	8	20

Code	D	d	d1	H	h	l	Weight gr.	Packing Pcs.
B1VZTM180620	18	M06	12	11	5	20	8	20
B1VZTM180630	18	M06	12	11	5	30	8	20
B1VZTM180640	18	M06	12	11	5	40	8	20
B1VZTM180650	18	M06	12	11	5	50	8	20